

STARBOARD PROFILE (WATERLINE VIEW)

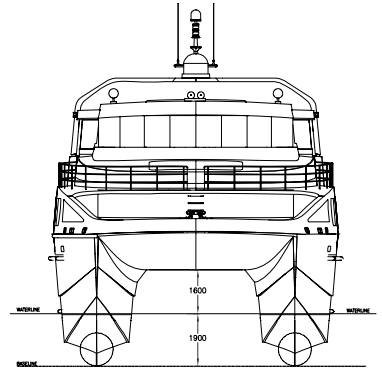

FORWARD VIEW

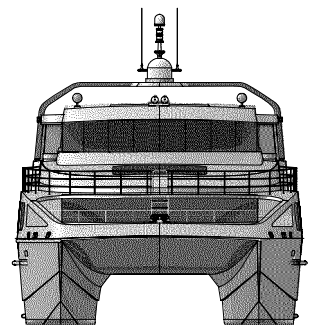
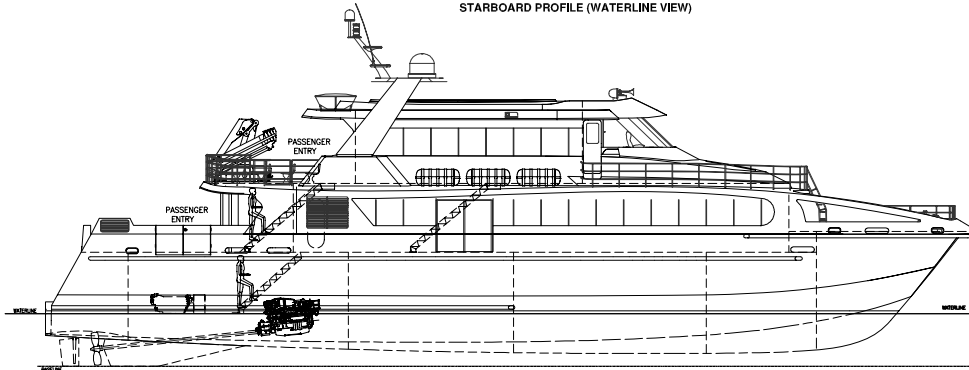

STARBOARD PROFILE

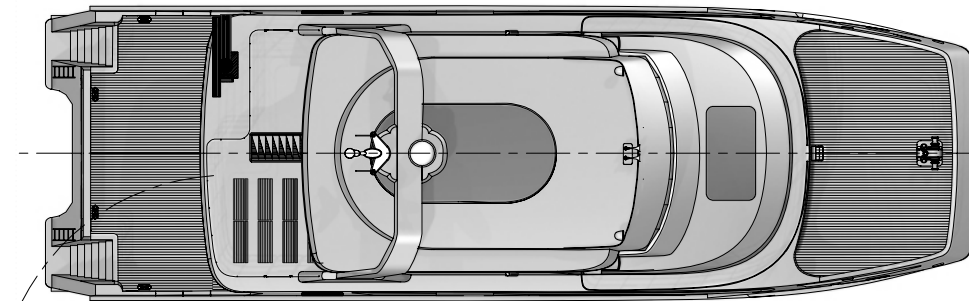

PLAN VIEW SHELL PLATING

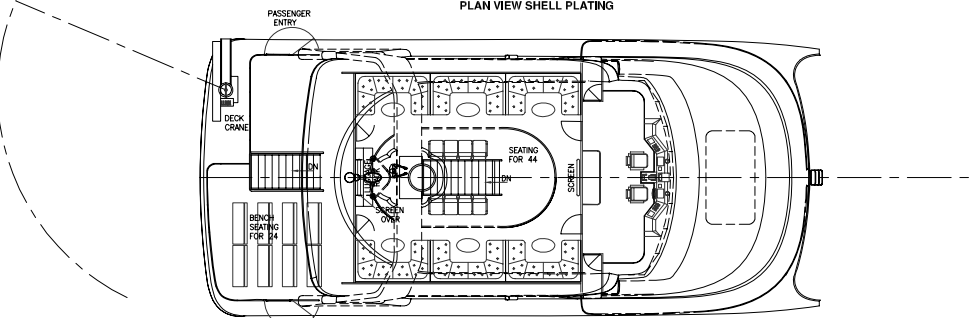

UPPER DECK PLAN

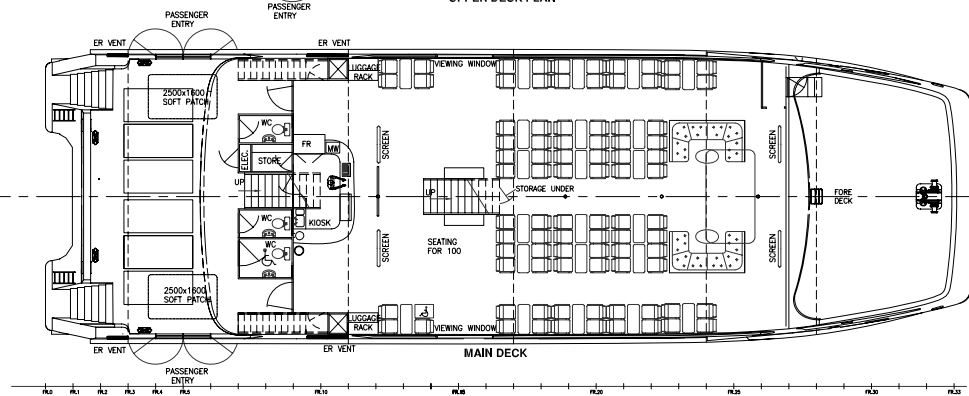

MAIN DECK

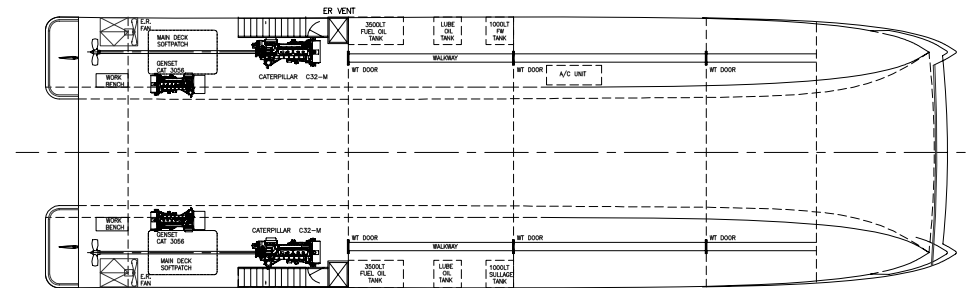

BELOW DECK

PRINCIPAL DIMENSIONS	
Length Overall.....	abt.....33.00m
Hull Length.....	30.80m
Hull Breadth.....	10.00m
Depth at Side.....	3.60m
Average Draught.....	1.90m
Number of Passengers.....	Approx. 150
Fuel Oil Tank Capacity.....	7,000 ltrs
Fresh Water Tanks.....	1,000 ltrs

CNA
 COMMERCIAL
 NAVAL ARCHITECTS
 COMMERCIAL NAVAL ARCHITECTS PTY LTD ACN 103 573 137
 P.O. BOX 666 MASTHEAD WAY
 SANCTUARY COVE QLD 4212
 AUSTRALIA
 TEL (07) 5577 9899
 FAX (07) 5577 8955
 WWW.NAVALARCHITECT.COM.AU

CLIENT
 PROJECT 33m ALUMINIUM HS CATAMARAN FERRY

TITLE
 GENERAL ARRANGEMENT (prelim)

DATE 21.07.05 DRAWN DJM/AR SCALE 1:100 DRG No. 984-G1 PAPER SIZE A1

REV	DATE	DESCRIPTION